

KALINLIK KOMPARATÖRÜ

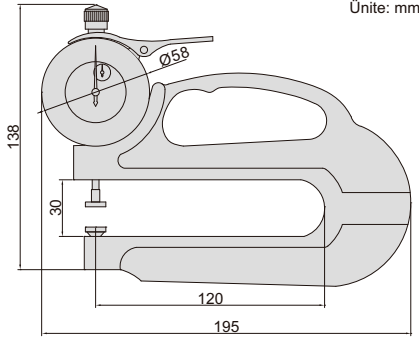
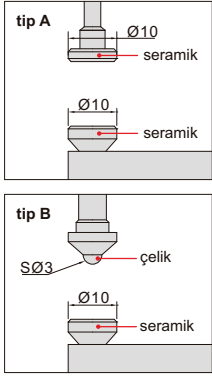

Kod	Ölçüm aralığı	Hassasiyet	Doğruluk	Tip
2365-10	0-10mm	0,01mm	±0,02mm	A
2365-20	0-20mm	0,01mm	±0,03mm	A
2365-10B	0-10mm	0,01mm	±0,02mm	B
2365-20B	0-20mm	0,01mm	±0,03mm	B

2365-10